

# BioSure

## PROFESSIONAL

### OWS-1

---

## Model EOS8131-CD Installation & Operation Manual

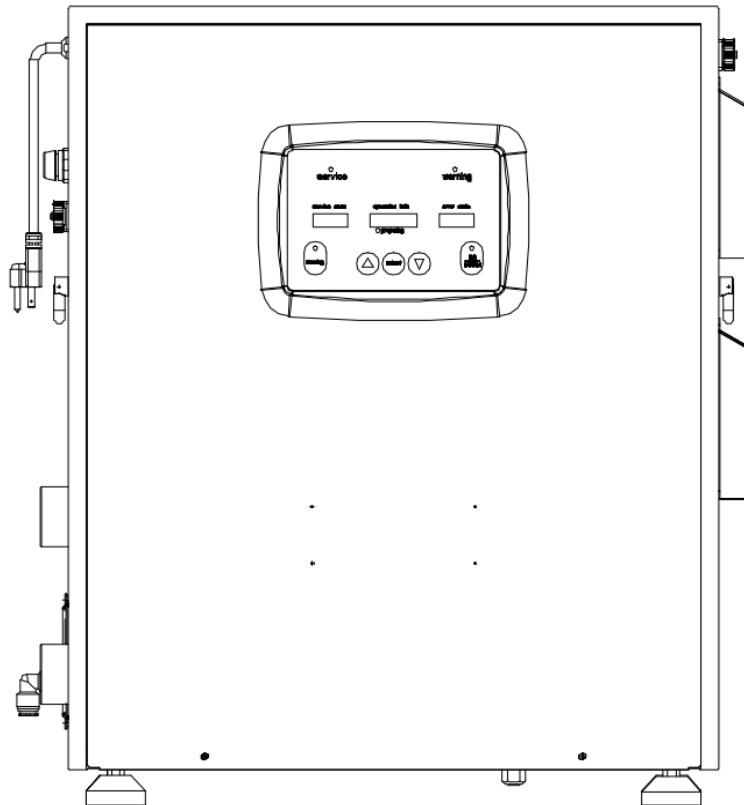

---

### Thank you for purchasing BioSure Professional product

Please read the instructions carefully and follow the safety precautions when using this product. Before using this product please pay special attention to the "IMPORTANT SAFETY INFORMATION" (P. 1~5). This product is intended to be used with an Ice Machine only ◦



## **PREFACE**

Described in this manual is the BioSure Professional Ozonated Water System OWS-1, model no.: EOS8131-CD.

BioSure Professional is a division of Biotek Environmental Science Ltd. (BES Group). BES Group is a global leading electrolytic product manufacturer with pioneering ozone application technology and currently holds over 60 patents for its electrolytic ozone generators and products worldwide.

## **COPYRIGHT**

©2019 Biotek Environmental Science Ltd. (BES Group)

All Rights Reserved.

Reproduction, adaptation, or translation without prior written permission is prohibited, except as allowed under the copyright laws.

Manual Number: 1st edition, April 2019

## **DISCLAMATION**

The information contained in this document is subject to change without notice.

BES Group shall not be liable for any direct, indirect, incidental, consequential, or other damage alleged in connection with the furnishing or use of this information. BES Group is not liable for damages on any contact materials due to result of oxidation.

BES Group makes no warranty of any kind with respect to this information. BES GROUP SPECIFICALLY DISCLAIMS THE IMPLIED WARRANTY OF MERCHANTABILITY AND FITNESS FOR A PARTICULAR PURPOSE.



# Index

Preface	1
Packaging Contents	4
Important Safety Instructions	5
<b>1. General Information</b>	<b>7</b>
1.1 Product Description	7
1.2 Ozone in Practice	8
1.3 Physical Properties of Ozone	8
1.4 Functional Descriptions	9
1.5 Intended Use	9
1.6 System Overview	10
1.7 Specifications	12
<b>2. Installation</b>	<b>14</b>
2.1. Pre-Installation	14
2.2. Location	14
2.3. iEOG Water Feed Pre-filtration	14
2.4. Electrical	15
2.5. Connection	15
2.6. Material Compatibility	19
<b>3. Operation</b>	<b>20</b>
3.1 Correct and Proper use	20
3.2 Descriptions of OIP Display and Button Functions	21
3.3 Pre-Commissioning Check	24
3.4 Initial Start-Up	24
3.5 Shut-down, Re-start & Power Disconnection Protection	25
3.6 Operation States	25
3.7 Conditionally Shut-Down Procedures	28
<b>4. Maintenance</b>	<b>29</b>
4.1 Service Notification	29
4.2 Preventative System Maintenance	30
4.3 System Servicing	31
4.4 System Operational Code	32
<b>5. Troubleshooting</b>	<b>34</b>
5.1 Error Notification	34
5.2 Troubleshooting Procedures	35
<b>6. Validation</b>	<b>37</b>

## Packaging Contents

Your OWS-1 comes with the following accessories. Check that all items are present. If anything is missing, please contact your dealer.

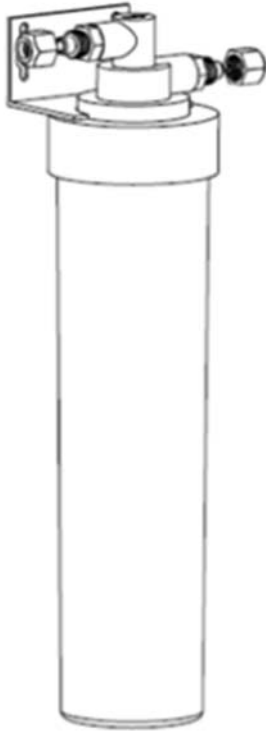

PF-120 Prefilter



iEOG Feed Water Pipe  
(3/8", PE, white, 2m)



Drain Pipe  
(7x10, PVC, Black, 2m)

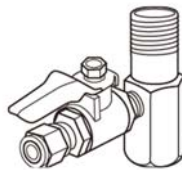

1/2" to 3/8" T-adaptor  
(with 3/8" ball valve)

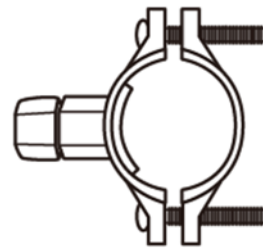

Drain Clamp

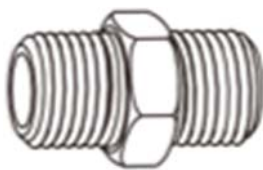

1.5" Screw Joint



Plumber's Tape



OM-100  
Dissolved Ozone Titration  
Ink

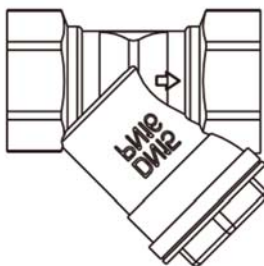

1.5" Y-Strainer  
(0.1mm Filtration)



Spare Pump Fuse

---

## IMPORTANT SAFETY INSTRUCTIONS

### READ ALL SAFETY WARNINGS & INSTRUCTIONS CAREFULLY BEFORE ATTEMPTING INSTALLATION, OPERATION OR SERVICING

#### Cautions and General Notes

- All service work must be performed by an authorized and qualified technician.
- Failure to install or operate in accordance with the instructions could void warranty and result in injury or product damage.
- All plumbing should be completely set up before plugging power to power on. Ensure all water inlets and outlets are connected to corresponding hoses and are properly installed.
- Ensure the input water pressure is within the range of  $3.0 \pm 1.0 \text{ kg/cm}^2$  ( $42.7 \pm 14.2 \text{ psi}$ ). To protect your investment, if the pressure exceeds  $4.5 \text{ kg/cm}^2$ , (64 PSI), a pressure regulator must be installed prior to input.
- Always make sure that all the connecting hoses allow free flow of water during operation.
- Risk of electric shock. Always use a well-grounded, 15A or above individual socket. Do NOT use loose or defective socket.
- To prevent accidental shock we recommend this product always be used on a GFCI (Ground fault Circuit Interrupter) outlet.
- Ensure the power supply meet the requirements as indicated in the product specifications. Follow all applicable electrical codes.
- Do NOT put the machine in water or spray water into it. Otherwise it may damage the unit or cause electric shock.
- Do NOT use a damaged power cord. Do NOT stretch, twist or tie power cord during use. Do NOT press power cord. To reduce the risk of electric shock, replace damaged cord immediately.
- Do NOT block the vent at the back and/or the two sides of the machine, as this will impair the efficiency of the system.
- Do NOT operate the system if:
  - The cord or plug is damaged.
  - There is no input water supply.
  - The system has malfunctioned.
- If there is any noticeable damage to the system, contact your regional distributor or authorized service agency for examination, repair or replacement.
- The system should be sized appropriately for its intended use by a qualified professional familiar with the application.
- Do not store or use gasoline, chemicals or other flammable liquids or vapors near this or any other appliance.

**SAVE THIS MANUAL FOR FUTURE REFERENCE**

## **Ozone Safety Practice**

Two aspects of BioSure Professional OWS-1 System represent attentions - Ozone Gas and Ozonated Water (Dissolved Ozone):

### **Ozone Gas**

**ATTENTION: Ozone gas is a potential hazard.**

BioSure Professional OWS-1 System generates ozonated water directly from tap water supply. The systems are designed to handle the ozone gas safely with built-in off-gas destructor to meet OSHA's maximum permissible exposure standards - 0.1 ppm within 8 hours / 0.3 ppm within 15 minutes. Ozone is detectable at very low concentrations (approx. 0.02 ppm), which is far below the permissible exposure levels.

Minimum ventilation is required for safety precautions as in some applications ozone gas may be evaporated from solution (ozonated water). The operation area should employ ventilation at minimum rate of 5 air changes per hour. In any cases if operators cannot ensure to maintain the minimum ventilation, installation of an ambient ozone monitor is recommended.

Short term inhalation of high concentrations of ozone and long term inhalation of low concentrations of ozone can cause serious harmful physiological effects. Do NOT inhale ozone gas produced by this device.

Hazardous levels of ozone may be trapped in the system after a fault condition or when power is turned off during operation. Always ensure ozone has been purged by allowing Ozone Generator to complete its shutdown sequence before servicing.

### **Ozonated Water (Dissolved Ozone)**

**ATTENTION: Concentrated ozonated water is NOT for drinking.**

BioSure Professional OWS-1 System is designed to provide ozonated water as a sanitizer.

Ozonated water is an approved safe sanitizer if applied properly. It is pH natural and the bacteria killing capacity is based on oxidation.

### **USDA & FDA Approval**

Ozone has been given GRAS (Generally Recognized as Safe) approval by the USDA and the FDA for direct contact with food contact surfaces and food products.

### **NOx-Free Guarantee**

Nitrogen Oxides are health hazards and is a typical by-products in traditional ozone technology (i.e., Corona Discharge). BioSure Professional applies electrolytic ozone technology which generates ozone without NOx. We warrants that our performance result are completely NOx-Free.

**SAVE THIS MANUAL FOR FUTURE REFERENCE**



# 1. GENERAL INFORMATION

## 1.1 Product Description

BioSure Professional Ozonated Water System OWS-1 is a sanitation system supplying ozonated water designed specifically for applications in food preparation or processing. The system offers the benefits of ozone in cold water in an effective and safe manner for integration with, and improvements of the existing sanitation processes and protocols.

O The OWS-1 applies BioSure Professional's Indirect Electrolytic Ozone Generation (iEOG) technology, which enables ozone to be formed steadily from water with NOx-free and 28wt% high concentration results. Such consistent production and high purity features allow us to provide a promoted ozonation treatment to water that flows through the system, feeding the output with dissolved ozone at concentrated effective levels. This technology ensures the given flow with dissolved ozone on demand at "Right on Spec" performance in the intended application.

The OWS-1 supports modular and point-of-entry application so that the unit can be easily integrated into a distribution system for ozone applications. The unit also supports a wide range of sanitation applications, enabling sanitation professionals to reduce or replace harsh chemicals and/or multi-step wash programs that may use expensive hot water previously. With cold-water program only that uses the power of dissolved ozone in water, a complete solution is offered to you not only for energy saving, but also for bacteria free water and chemical-free sanitation in your need!

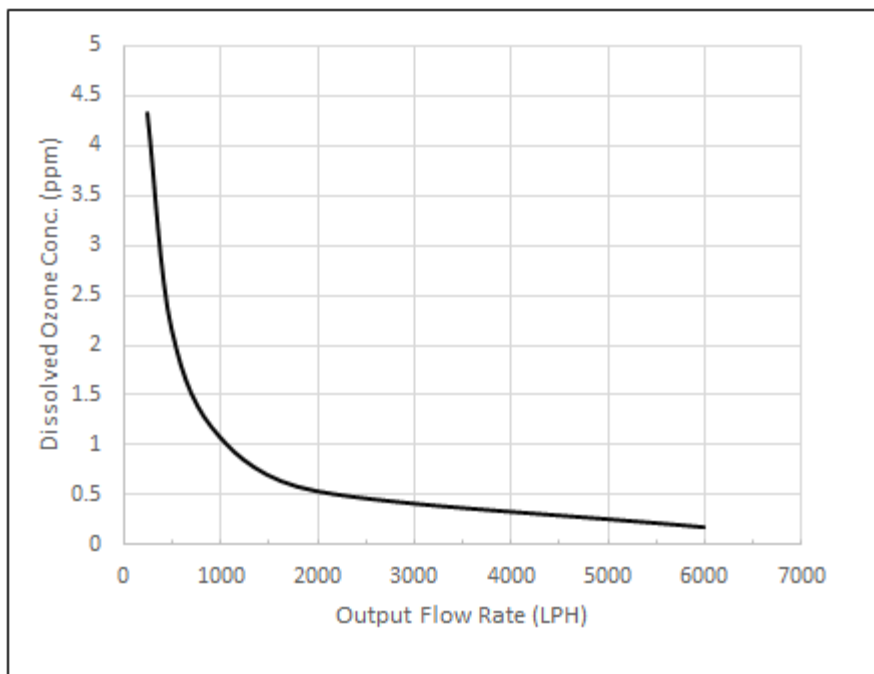

**Note: Consult your local BioSure Professional dealer for specific application recommendation with respect to the output concentrations.**

## 1.2 Ozone in Practice

Ozone itself is a colorless gas with a pungent smell. It is one of the strongest known oxidizing agents. It has an electrochemical oxidation potential of 2.08 V. The ozone molecule is only moderately stable and has a half-life in pure water and under normal operating conditions of about 20 minutes. In the absence of oxidizable substances, ozone decays to oxygen. In the presence of oxidizable substances, traces of CO<sub>2</sub> will also be formed.

Many years of experience show that an average ozone concentration of about 0.1 to 0.2 ppm (mg/L) is sufficient to maintain the colony forming unit (cfu) count in pure water systems below 1 cfu per 100 ml.

## 1.3 Physical Properties of Ozone

<b>Molecular weight</b>	47.9982	g/Mol
<b>Density under normal conditions</b>	2.144	g/L
<b>Relative density</b>	1.5582	g/L
<b>Molecular volume under normal</b>	22.387	m <sup>3</sup> /kMol
<b>Boiling point (760 mm Hg)</b>	-111.9 ± 0.3	°C
<b>Melting point</b>	-192.7 ± 0.2	°C
<b>Critical temperature</b>	-12.1 ± 0.1	°C
<b>Critical pressure</b>	54.6	atm.
<b>Critical volume</b>	111	cm <sup>3</sup> /Mol
<b>Heat of vaporization</b>	75.6	cal/g
<b>Free energy (25 °C)</b>	32.4	Kcal/Mol

\*Normal conditions acc. to DIN1343: P<sub>n</sub> = 1.01325 bar; T<sub>n</sub> = 273.15°C, t<sub>n</sub> = 0°C

## 1.4 Functional Descriptions

Ozone (O<sub>3</sub>) is an active and unstable molecule consisting of three oxygen atoms. It is a strong oxidizing agent, which is classed as particularly environmentally friendly as it breaks down into oxygen. It is used especially in water for sanitation and disinfection purposes.

The BioSure Professional OWS Series System produces ozone electrolytically from water, and then dissolves ozone using a Self-priming Gas-liquid Mixing Pump. The water in the system is purified by reverse osmosis and ion-exchange and then dissociated by electrolysis. The electrolytic cell uses a solid polymer membrane as electrolyte. Using this membrane technology ozone can be produced by electrolysis from demineralized water.

The main advantages of ozone production with a BioSure Professional's electrolytic ozone generator are as follows:

- Steady and concentrated ozone output promotes ozone dissolution and reactions.
- No feed gas preparation, as the ozone is produced from water by electrolysis.
- Performance independent to air (air quality, humidity and flow).
- No Nitric Oxides (NO<sub>x</sub>) formation (or formation of Nitrous Acid in water).
- No pure water input, as the pure water is self-prepared by the systems.
- No ionic contamination, as the water is dissociated using a solid polymer electrolyte.
- Easy integration and operation.

## 1.5 Intended Use

### Applications

The BioSure Professional OWS-1 system produces ozonated water for all types of industrial applications:

- Bottled Water Manufacturing
- Beverage Manufacturing
- Pharmaceutical Manufacturing
- Cosmetic Manufacturing
- Semi-Conductor Industry
- Personal Product Industry
- Foodstuffs Industry
- Industrial Cleaning Processes
- etc.

The OWS-1 is designed as a ozonated water generation system that can work with BioSure Professional's G Series ozone system for added ozone capacity - up to 30 g/hr including self-produced. Contact BioSure Professional for more information.

## 1.6 System Overview

Refer to Figure 1 & 2 below for an overview of the system, connections and panel descriptions. Labels are provided on the system near selected connections to assist in proper installation.

### System Dimension, Parts & Connection

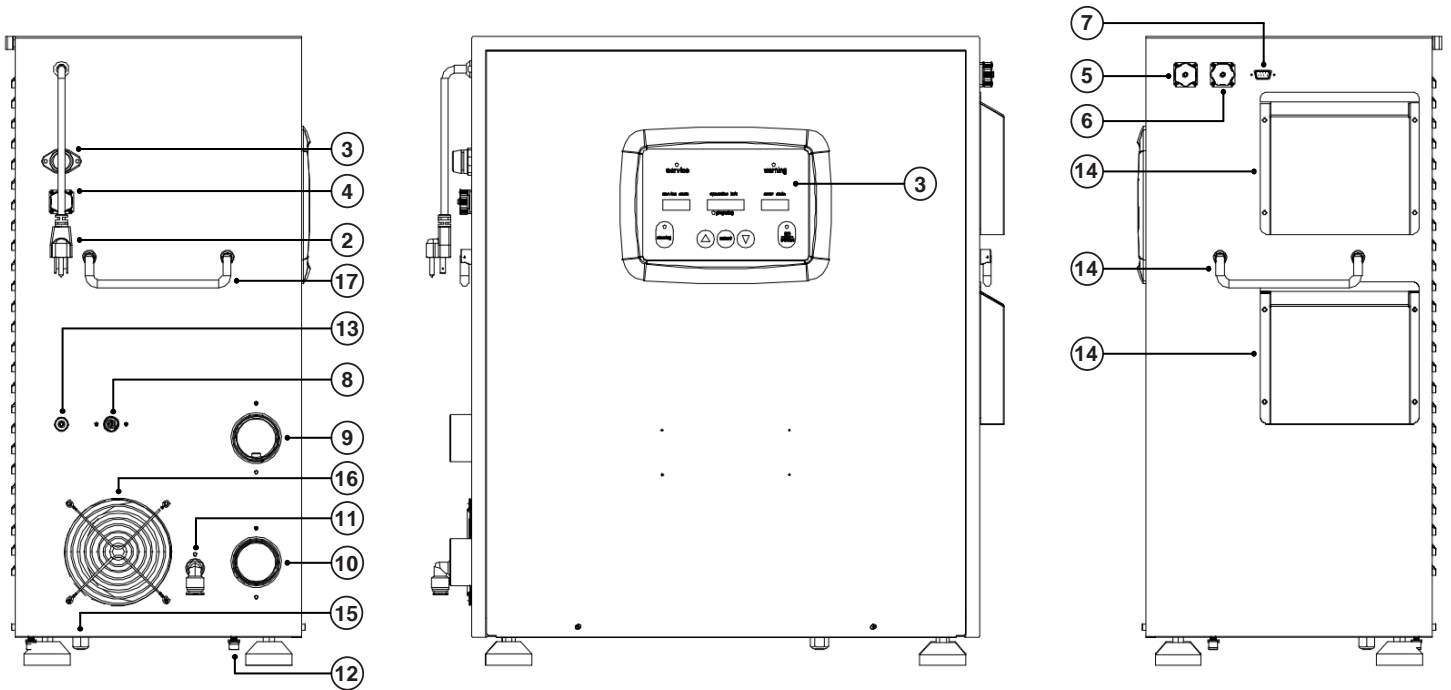
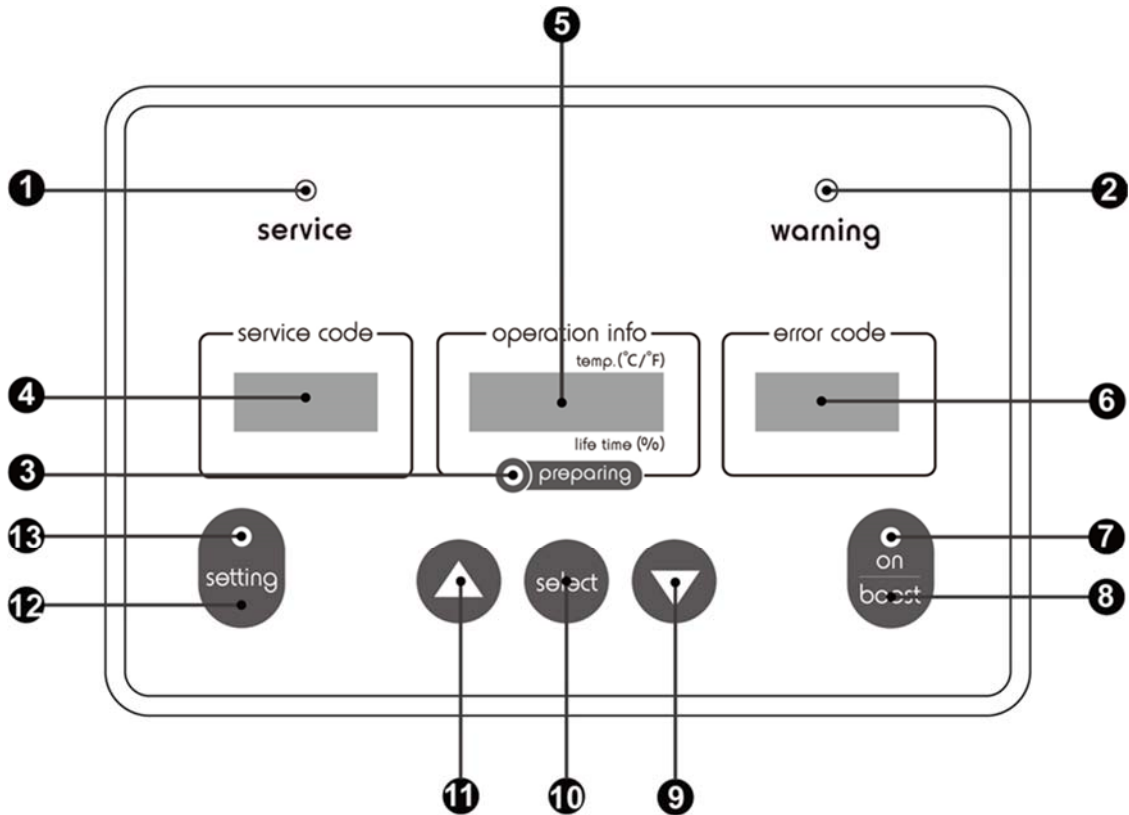

**Figure 1. OWS-1 Dimension Drawing Showing Connections**

### Captions

- |  |  |
|--|--|
| 1. Operator Interface Panel (OIP)          | 10. Ozonated Water Service Outlet, R1 1.5" |
| 2. Power Cord & Plug (1.5m)                | 11. Drain Outlet, 7x10                     |
| 3. Pump Fuse                               | 12. Exhaust Outlet (Oxygen)                |
| 4. External Circuit Control Port (ON/OFF)  | 13. Add-ozone Inlet, 3/8"                  |
| 5. Parallel Communication Port (G Series)  | 14. Side Air Inlet                         |
| 6. External Signal Control Port (DC 5-12V) | 15. Bottom Air Inlet                       |
| 7. Programming Port (DB9)                  | 16. Air Outlet                             |
| 8. iEOG Feed Water Inlet, 3/8"             | 17. Carry Handle(s)                        |
| 9. Mixing Water Service Inlet, 1.5         |  |

## Operator Interface Panel (OIP) Descriptions



**Figure 2. OWS-1 Operator Interface Panel (OIP) Descriptions**

### Captions

- |                                 |                               |
|---------------------------------|-------------------------------|
| 1. Service indicator (Yellow)   | 8. [Cancelled Button]         |
| 2. Warning indicator (Yellow)   | 9. Page-Down key              |
| 3. Preparing indicator (Green)  | 10. Select/Enter key          |
| 4. Service code screen          | 11. Page-Up key               |
| 5. Operation information screen | 12. Setting key               |
| 6. Error code screen            | 13. Setting indicator (Green) |
| 7. Operation indicator (Green)  |                               |

## 1.7 Specifications

Engineering Configurations	
<b>System Model Number</b>	OWS-1 (EOS8131-CD)
<b>Type of Ozone Generator</b>	Indirect electrolytic ozone generation (iEOG)
<b>Ozone Generation Source</b>	Water (municipally treated water)
<b>Principle of Setup</b>	Central, stationary type (Point of Entry, POE)
<b>Start Control Method</b>	Flow start (>200LPH)
<b>Dissolving Method</b>	304 Stainless steel self-priming gas-liquid pump
<b>Off-gas handling</b>	Built-in thermal catalytic process
<b>Cooling Configuration</b>	Air cool
<b>IP Code</b>	IP-X2
<b>Noise Level</b>	Max. 60 -65 bB (at 1 m or 3.3 ft)

Dimensions and Weight		
<b>Dimension</b> (WxDxH)	mm	550 x 310 x 680 (leg height: 30)
	inch	21.7 x 12.2 x 25.6 (leg height: 1.2)
<b>Net Weight</b> (Approx.)	Kg	50.0
	lbs	110.2
<b>Packaging Weight</b> (Approx.)	Kg	65.0
	lbs	143.3

Location Requirements	
<b>Location</b>	For use on a hard, level, and stable surface only
<b>Ambient Temperature</b>	5 ~ 40°C (41 ~ 104°F)
<b>Ventilation</b>	Min. 5 air changes per hour
<b>Clearance</b>	Min. 10 cm (4") clearance around unit

Power Requirements	
Applied Power	AC 100 - 120V 50Hz AC 220 - 240V 50Hz AC 220 - 240V 60Hz
Standby Power Consumption	200W
Rated Power	950W @ AC100 - 120V / 750W @ AC 220 - 240V
Input Water Requirements - iEOG Feed Water	
Pressure	2.0 - 7.0 kg/cm <sup>2</sup> (28.5 - 99.5 psi)
Flow Rate	≥ 500 LPH (2.2 GPM)
Temperature	5 ~ 35 °C (41 ~ 95 °F)
Water Quality <sup>1</sup>	pH 6~8; Conductivity ≤ 500µs/cm; Chlorine residual ≤ 0.1ppm
<b>Note:</b>	
1. Municipally treated tap water, chlorine removed and filtered to 1µm.	

Input Water Requirements - Mixing Water Input		
Pressure <sup>1</sup>	3.0 ± 1.0 kg/cm <sup>2</sup> (42.7 ± 14.2 psi)	
Flow Rate	Maximum	6000 LPH (17.61 GPM)
	Minimum	200 LPH (0.88 GPM)
Temperature	5 ~ 35 °C (41 ~ 95 °F)	
Water Quality <sup>2</sup>	Tap water; Filtered to 0.1mm	
<b>Note:</b>		
1. If the input pressure may exceed 4.5 kg/cm <sup>2</sup> or 64.0 psi, a pressure-reducing valve must be attached in the mixing water input. Using pressure-reducing valve will reduce the maximum output flow.		
2. Municipally treated tap water with Y-strainer attached in the input for particle filtration.		

Output Water Characteristics	
Output Feature	Ozonated water
Flow Capacity*	200 ~ 6000 LPH (0.88 ~ 17.61 GPM)
Outflow Pressure	≤ Input water pressure (max. 4 kg/cm <sup>2</sup> , 56.9 psi)

---

## 2. INSTALLATION

Consult your local BioSure Professional dealer for installation arrangements. The information described below in this section is intended for operator's reference.

The most common configurations for common installation sites are discussed in this section. For additional installation options or questions on your specific installation, please contact your regional BioSure Professional dealer.

### 2.1. Pre-installation

Inspect the location for installation. Check for:

- Space for the unit / Ventilation / ambient temperature
- Water supply flow and pressure
- Drain availability
- Power supply availability

Refer to the product specifications in Section 1.7 (P. 12) for all the requirements and detail.

### 2.2. Location

The OWS-1 is designed for location on the floor or support plate. Place the unit on a flat and stable or similar placement surface to prevent toppling and falling. Locate the unit out of reach of water splash and airborne water with a degree of protection from dirt or other containments. Allow sufficient access for maintenance and all piping. Other key requirements of the location are as follows (Refer to Section 1.7, P. 12):

- Well ventilation - min. 5 air changes per hour
- A 10 cm (4") minimum free air space must be maintained on all sides
- Climate-controlled, ambient temperature of 5° to 40°C (41° to 104°F)

### 2.3. iEOG Water Feed Pre-filtration

For water that enters the unit as input for iEOG water feed, the water quality must meet our standards as follows:

- Municipally treated tap water
- pH between 6 and 8
- Temperature between 5 ~ 35 °C (41 ~ 95 °F)
- Water conductivity below 500 µs/cm
- Filtered to 1µm
- Chlorine residual below 0.1 ppm

BioSure Professional recommends that pre-filtration be installed on our products for the input to the iEOG water feed. In most cases, treatment is needed to address the removal of dirt, debris, sediment and chlorine residual. This stabilizes the iEOG process resulting in maintained performance.



The type of pre-filtration may vary with local water quality. Please see your local BioSure Professional distributor for the best recommendation for your area.

**Note:**

1. **Check near the unit to locate a solid wall surface to mount a pre-filter for iEOG water feed input.**
2. **The iEOG feed water pre-filter must be mounted in a vertical position. For cold water line only.**
3. **Filtration, or treatment, must be sized properly to be effective. Inadequate flow and pressure will cause problem with operation of the unit.**

## 2.4. Electrical

The OWS-1 is supplied with a standard power cord. Plug the cord into a standard grounded, grounding type receptacle only. Refer to specifications of the unit (Refer to Section 1.7, P. 12) and your local electrical codes for information on proper electrical connection. All permanent electrical connections should be made by a qualified electrician.

**Note: The circuit must be protected by a GFCI (Ground fault Circuit Interrupter) installed in accordance with electrical codes.**

There is no ON/OFF switch on the unit. The unit is switched ON by plugging the power cord into a wall outlet. Before plugging the unit to start, all plumbing should be completed first. °

## 2.5. Connection

### Parts & Hardware included (accessories)



- 1.5" Y-Strainer
- 1.5" Screw Joint
- iEOG Feed Water Pre-Filter with Mounting Kits (PF-120)
- 3/8" PE iEOG Water Feed Pipe, 2 m (white)
- $\phi 7 \times 10$  mm PVC Drain Pipe, 2 m (black)
- Connecting T-Adaptor (1/2" to 3/8" three-way adaptor & 3/8" ball valve)
- Drain Clamp
- Plumber's Tape (Teflon)
- Spare Pump Fuse
- OM-100 Dissolved Ozone Titration Ink

### Tools & Materials Required



- Safety glasses
- Phillips screwdriver, adjustable wrench and utility knife
- Tape measure and pencil or marker
- Pan or bucket and newspaper or towels
- Electric drill (cordless recommended)
- Shut off valves (for isolation setup)
- Piping materials (for mixing water input and system output connection or extension)

### Optional Materials



- Pipe cutter
- 6 mm drill bit (for pre-filter mounting installation)

### Recommended Installation Schemes (Typical Installation Diagram)

Unless you have a reason for doing otherwise, we recommend that you follow the below principles for your installations:

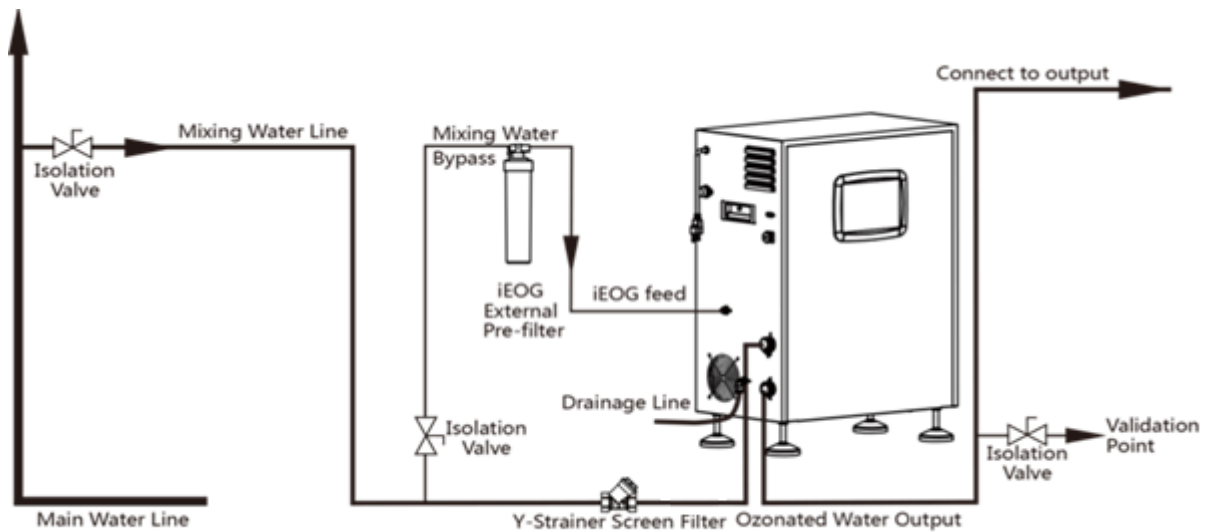

**Figure 3. Typical Installation Diagram of OWS-1 (EOS8131-CD)**

### Mixing Water Input and Ozonated Water Output

Smaller diameter pipe will increase dynamic flow loss in the output performance:

Pipe Diameter	Capable flow rate (max.)
1½"	5800 ~ 6000 LPH (17.2 ~ 17.6 GPM)
1"	3800 ~ 4000 LPH (17.2 ~ 17.6 GPM)
¾"	2600 ~ 2700 LPH (11.4 ~ 11.9 GPM)
½"	1300 ~ 1400 LPH (5.7 ~ 6.2 GPM)

**[Data based on input pressure at 3 kg/cm<sup>2</sup> (42.7 psi)]**

**Main Water In (Mixing Water)**

- 1.5" Thread Connection.
- Refer to specifications for water quality requirements.

**Main Water Out (Ozonated Water)**

- 1.5" Thread Connection.
- Refer to specifications for water quality requirements.

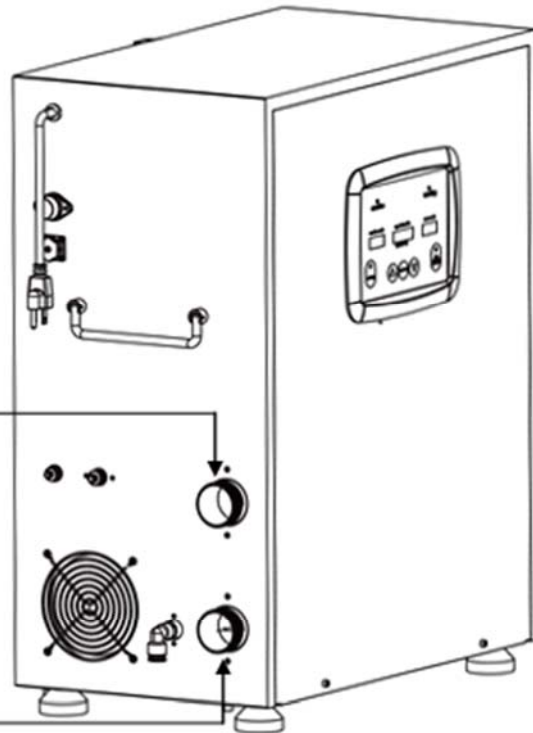

**iEOG Feed Water In**

- Press Connection.
- 3/8" PE tube (white), included accessory.
- Refer to specifications for water quality requirements.

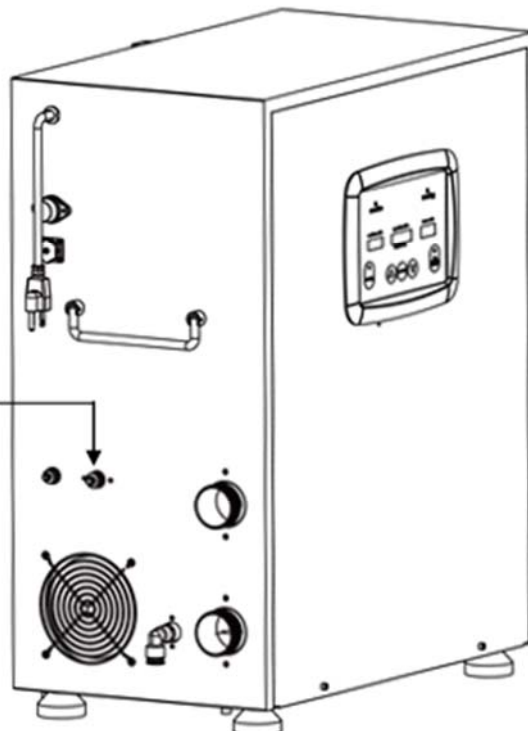

**Alternative Control Connections**

**Model 1 - Operated with BioSure Professional G Series**

*Note: This complementary control wiring plug is an optional accessory. Please contact your local BioSure Professional distributor to order this accessory if so needed.*

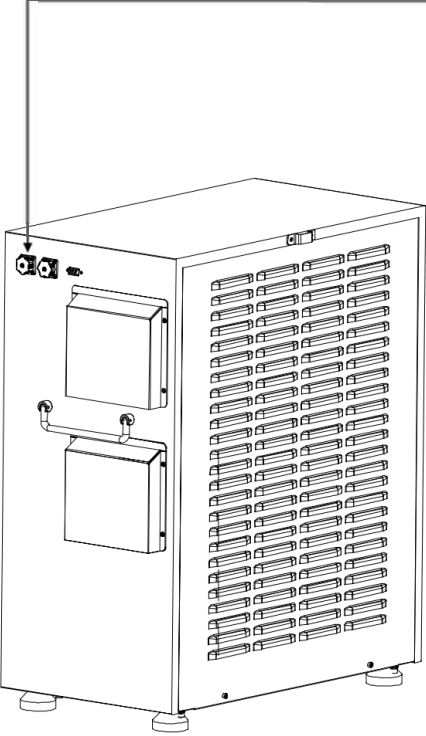

OWS-1 (EOS8131-CD)

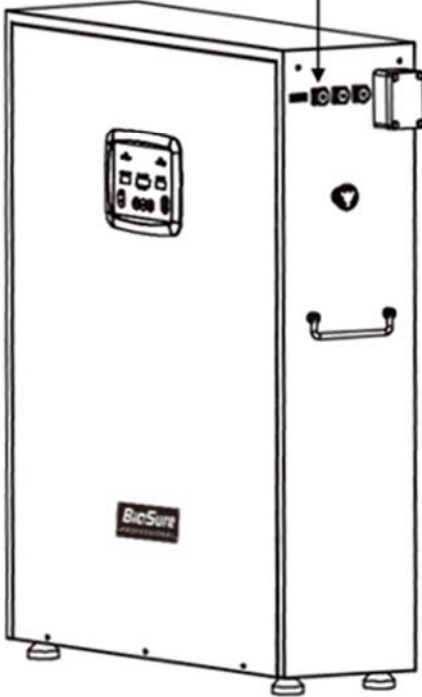

G Series (EOS8131-CL) Shown

**Added Ozone in**

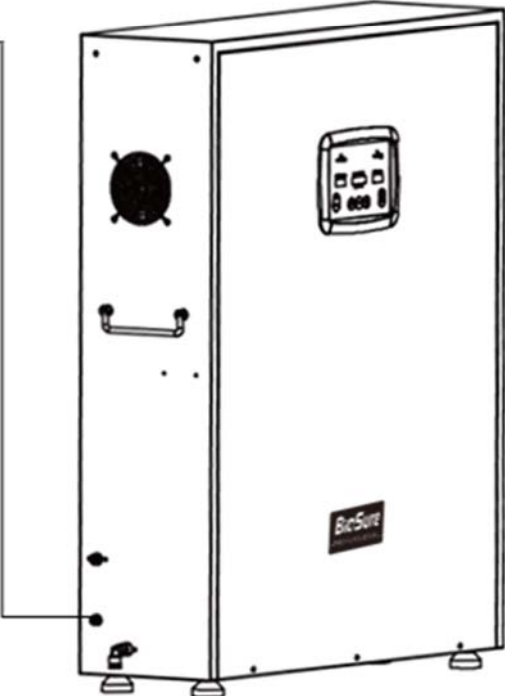
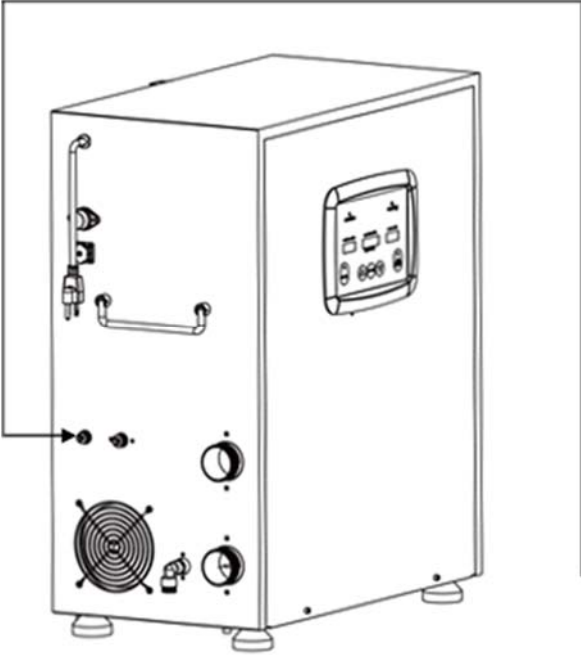

## Model 2 - Operated with an External Signal DC 5-12V

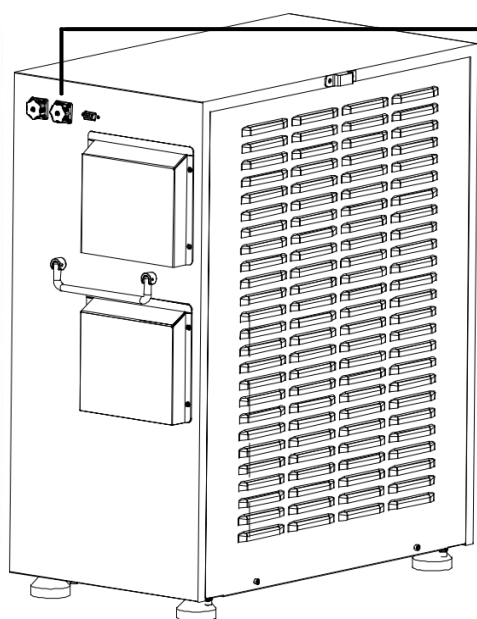

Supply DC 5-12V to switch off operation.

Application: Safety control from ambient ozone monitor

**Note: This complementary control wiring plug is an optional accessory. Please contact your local BioSure Professional distributor to order this accessory if so needed.**

## Model 3 - Operated with a Closed Contact Switch (ON/OFF)

Supply a closed contact for normal operation.

Application: Remote Main switch or timer control

**Note: This complementary control wiring plug is an optional accessory. Please contact your local BioSure Professional distributor to order this accessory if so needed.**

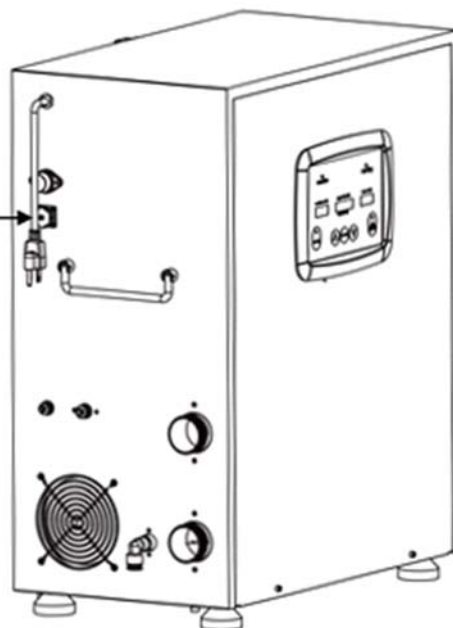

## 2.6. Material Compatibility

In order to avoid ozone leaks, all materials coming into contact with ozone must be completely ozone compatible. Acceptable materials include stainless steel, glass, Hypalon, Teflon (PTFE), PVDF, etc.

As a general rule, the following minimum material qualities are recommended:

- Stainless steel ASTM 316 L for wet ozone gas
- PTFE, PVDF or Viton Gaskets for wet and dry ozone gas

## 3. OPERATION

### 3.1 Correct and Proper Use

As a result of proper use of the BioSure Professional OWS-1, unpleasant effects of traditional chemical use can be virtually eliminated, and you may save much more expensive hot water, too. The OWS-1 can be so reliable to you and is safe and harmless to your equipment when installed and operated properly!

- It is recommended to always remain the OWS-1 connected to the supply of power and water AT ALL TIMES.
- The OWS-1 is intended solely to apply cold, municipally treated tap water as input for operation. The key criteria considered for the quality of the input water are as follows:
- Connecting to a water source with supply pressure at **3.0 kg/cm<sup>2</sup> (42.7 psi)** is preferably recommended for the best system performance.
- If the mixing water input pressure **may exceed 4.5 kg/cm<sup>2</sup> (64.0 psi)**, an external pressure-reducing valve must be applied. This part is NOT included in the accessories.
- Installation in an environment where temperatures may exceed 40°C (104°F) can impair cooling performance and may result in system overheat. The system will shut down automatically for protection once inside temperature reaches 56°C.
- If the system is installed in an environment with temperature over 40°C (104°F), an additional air-cooling must be provided. Operating outside of the recommended temperature range may result in damage not covered under the product's warranty.
- The system must be protected from freezing, which can cause cracking of the system's parts and water leakage.
- The system should NOT be operated in conditions other than those described in this manual (refer to specifications).
- The system is not intended for operation outside. However, if it is so necessary for outdoor installations, protection from the weather elements (direct sun, rain, dirt) must be provided.
- The system is not intended for portable operation but for stationary only.
- The correct and proper operation of the system cannot be guaranteed if non-genuine parts or third party accessories are used.
- Please read and observe the service requirements to keep the machine in good working order.

### 3.2 Descriptions of OIP Display and Button Functions

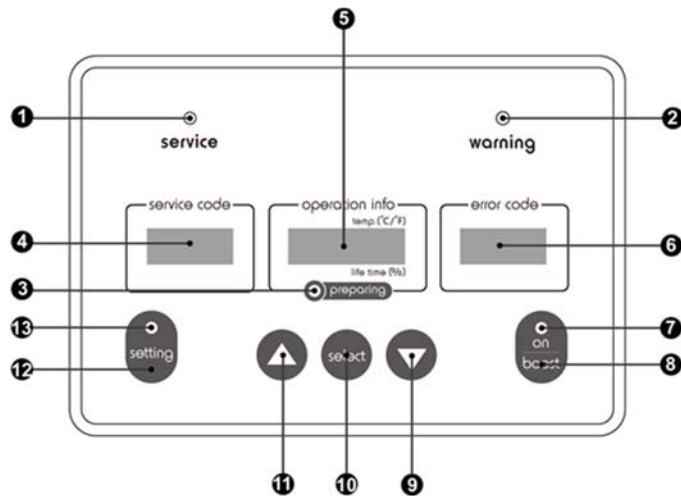

1. Service Indicator (Yellow)
2. Warning Indicator (Yellow)
3. Preparing Indicator (Green)
4. Service Code Screen
5. Operation Information Screen
6. Error Code Screen
7. Operation Indicator (Green)
8. [Cancelled Button]
9. Page-Down Key
10. Select/Enter Key
11. Page-Up Key
12. Setting Key
13. Setting Indicator (Green)

#### “Service” Indicator (Yellow)

At the top-left corner is the “Service Indicator”, flashing in two modes to indicate the service is required and the degree of urgency to the requirement:

LED Mode	Interpretation
Slow Flashing Yellow [On 0.5S/Off 0.5S]	Servicing parts approaching the end of lifecycle (2% remaining).
Quick Flashing Yellow [On 0.1S/Off 0.2S]	Servicing parts reached the end of lifecycle.

#### “Warning” Indicator (Yellow)

At the top-right corner is the “Warning Indicator”, flashing to indicate an error and the unit has stopped operating:

LED Mode	Interpretation
Quick Flashing Yellow [On 0.1S/Off 0.2S]	Error encountered and operation is stopped.

#### “Preparing” Indicator (Green)

The “Preparing Indicator” will light solid-on or flash to indicate three different status for iEOG’s preparation conditions:

LED Mode	Interpretation
Solid ON Green	iEOG preparation in process (pure water refilling).

Slow Flashing Green [On 0.5S/Off 0.5S]	iEOG re-start protection (30 min suspended).
Quick Flashing Green [On 0.1S/Off 0.2S]	iEOG preparation failure (PS. plus flashing warning).

### “Service Code” Screen

When service is due, together with flashing service indicator, this screen displays service code to notify the required item(s) for replacement.

In addition, it will also display a number from 1 to 7 together with display of “Operational Code” in “Operation Info” screen. As the “Operational Code” are divided and displayed in groups of 7, here this number from 1 to 7 is displayed for identification of the group numbers (Refer to Service Manual in addition).

Readings/Display	Display Conditions
Service Code	Indicate which part is required for replacement when Service Indicator starts flashing.
Operational Code Group Number	Associated with Operational Code, display numbers from 1 to 7 to identify the groups.

### “Operation Info” Screen

In the middle of the three screens is for “Operation Information” that can provide information about various operational data:

Readings/Display	Display Conditions
Temperature	Under normal conditions (including normal standby and running), display water temperature inside the unit. Use “▲” (page-up) or “▼” (page-down) key under standby mode to switch between degree Celsius (°C) and Fahrenheit (°F) in the display based on preference.
Part’s Remaining Life-span	Press “select” to display the remaining life span for each consumable part. Use “▲” (page-up) or “▼” (page-down) key under standby mode to roll up or down. Press “select” again to return.
Operational Code	Press “setting” (hold 15 sec) to display the Operation Codes for operating history. Refer to P.32 for further detail.

### “Error Code” Screen

On the far right of the three screens is for “Error Code” that will display error codes to notify the occurrence of any self-detectable problems.



**“ON” Indicator (Green)**

At the right-bottom corner, on the “On/Boost” button is the “On” Indicator that will light solid on when the unit is running under normal conditions:

LED Mode	Interpretation
Solid ON Green	System running.

**“Select” Key**

This button is used for operators to switch the display between the “Temperature” and “Part Remaining Life-time”. Also, it can be used to cancel the display of “Operational Code”:

Function	Conditions / Outcomes
Part Remaining Life Span Display (Press 0.3S)	To display the Part Remaining Life-Time in the “Operation Info” screen. Use “▲” (page-up) or “▼” (page down) key to switch the display of between each part. Press the “select” again to return to standby with temperature display.
Operational Code Display Cancellation (Press 0.3S)	To cancel the Operational Codes display.

**“Setting” Key**

The “setting” button is used for operators to activate the display of “Operational Code”:

Function	Conditions / Outcomes
Operation Code (Press 15S)	Press and hold on the key for 15 seconds to activate the display of Operation Codes. Use “▲” (page-up) or “▼” (page down) key to switch between each displayed codes group (7 groups in total). Press “select” to return.

**“Setting” indicator (Green)**

At the left-bottom corner, on the “setting” button is the “Setting Indicator” that will flash slowly when the “Operational Code” is displayed.

LED Mode	Interpretation
Slow Flashing Green [On 0.5S/Off 0.5S]	Indicate “Operational Code” is being displayed.

## Summary of Button Functions

Functions	Operation Instructions
Switch temperature between °C and °F	<ul style="list-style-type: none"> <li>Press “▲” (page-up) or “▼” (page-down) key under standby mode.</li> </ul>
Display part remaining life-time information	<ul style="list-style-type: none"> <li>Press “select” key under standby mode (Temperature display).</li> <li>Use “▲” (page-up) or “▼” (page-down) key to display data.</li> <li>Press “setting” key to return.</li> </ul>
Display operational code	<ul style="list-style-type: none"> <li>Press and hold on the “setting” key for 15 seconds to display the system operation codes.</li> <li>Use “▲” (page-up) or “▼” (page-down) key to switch between each displayed codes group.</li> <li>Press “select” key to return.</li> </ul>

### 3.3 Pre-Commissioning Check

Confirm all below points prior to start-up:

- All inputs, output and drain are correctly installed to their corresponding connections.
- The power supply meets the requirements as indicated in the product specifications.
- Input water pressure of iEOG feed water is 2-7 kg/cm<sup>2</sup>.
- Input water pressure of mixing water is 2-4 kg/cm<sup>2</sup>.
- The area of operation is well ventilated (Min. 5 air changes per hour).

### 3.4 Initial Start-Up

The system is switched ON by plugging the power cord into a wall outlet (power supply). There is no ON/OFF control switch. Before plugging the unit into the wall outlet, all plumbing works should be completely set up.

To use the machine at the first time, connect the machine to power to switch on and the “preparing” light will begin to flash slowly. At this point, the machine is in preparation stage refilling purified water for **iEOG start-up**. This process will take about 40 to 60 minutes depending on models and on-site water pressure.

**Note: System draining during this stage is normal.**

Once this preparation phase is complete, the “preparing” light will go out automatically, and the system is now ready for normal operation. At this point, the panel displays the detected water temperature inside the system on the “Operation Info” screen.

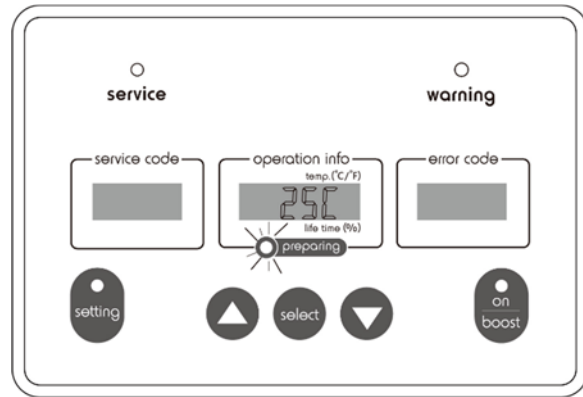

However, if in two hours the initial water filling process for iEOG start-up cannot be completed, a “E45” error code will be displayed, indicating that the water filling process was unsuccessful. All functions will remain suspended. Please check the input water pressure and refer to the troubleshooting section on P.34 if the symptom is identified.

### 3.5 Shut-down, Re-Start & Power Disconnection Protection

The system is intended for being power connected and switched on at all times, unless in necessary situations, such as to stop the unit for service or relocation. The unit can be switched OFF by un-plugging the cord from wall outlet (power supply). Before shutting down the unit, the water supply to the unit should be completely turned off.

**Note: Disconnecting the power too often may cause unexpected impacts on the iEOG module, which may result in degradation to the product performance.**

To re-start the unit, simply reconnect the unit to power for switching on. However, after re-start all functions will be suspended for 30 minutes. This is a standard protection procedure to minimize the impacts on the iEOG-working module. During this “PROTECTION” period, system is running program for check and maintenance.

### 3.6 Operation States

#### Starting and Running

By default, the OWS-1 units are flow-starting systems. Once sufficient open outflow is allowed and detected ( $\geq 200$  LPH; 0.88 GPM), the unit enters the “Running State” automatically, which is also indicated on the control panel with “On” indicator lighting solid on green. In this state, the pump is running and ozone is being dissolved in the mixing water stream. The delivery of dissolution will continue until flow switch indicates insufficient or no demand for output.

## Temperature Setting

The OWS-1 measures water temperature inside the unit and displays it on the “Operation Info” screen for operator’s reference. This display under all states as a primary display comes as default in any new unit. You can press “▲” (page-up) or “▼” (page-down) under standby mode to switch the unit between degree Celsius (°C) and Fahrenheit (°F).

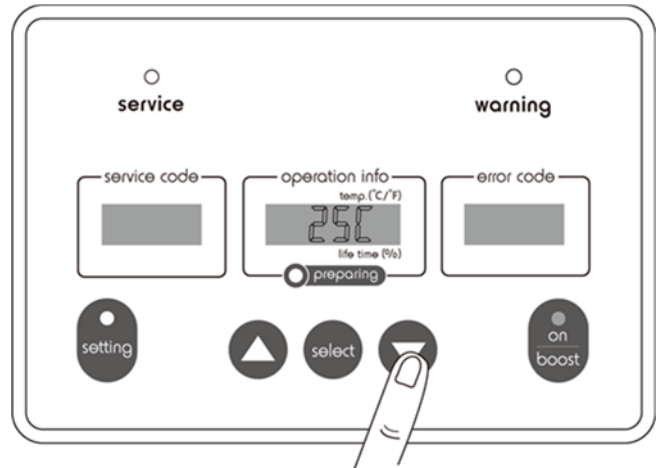

## Display of Parts Life Cycle

The OWS-1 records **Remaining Life Cycle** of each consumable part for operator’s reference. The information is displayed on the “**operation info**” screen. Under standby mode, press “**select**” button to switch the display for between the measured water temperature and **Remaining Life Cycle** Information of each consumable part. The first two codes represent the part and the following two indicate the **Remaining Life Cycle** in percentage (%). Press “▲” (page-up) or “▼” (page-down) to switch the display for each of the consumable parts equipped in the units for regular check purpose.

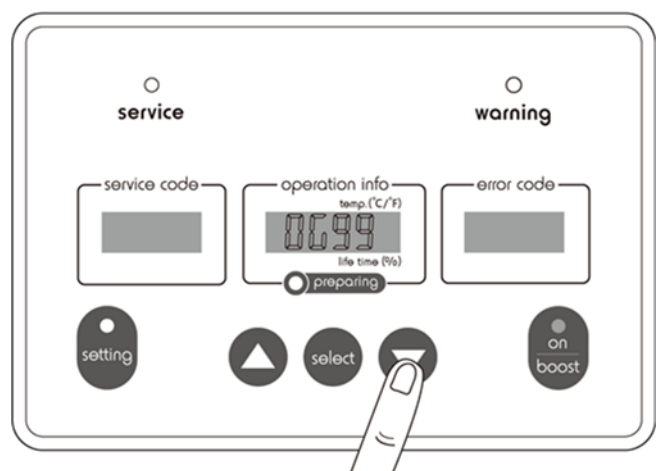

The coding system for the **Remaining Life Cycle** display is interpreted as follows :

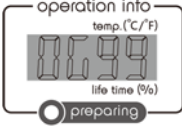
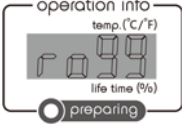
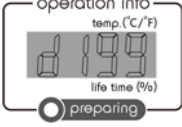
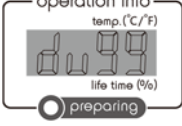
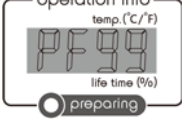
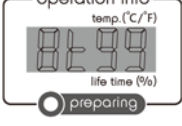
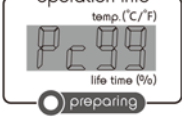
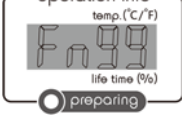
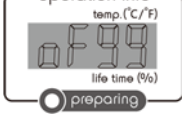
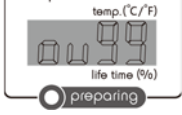
Coding	Interpretation
	<p>Wording translation: <b>OG99</b>  Indicated part: <b>EOG Cell(s)</b>  Interpretation: Remaining life 99% for EOG Cell(s)</p>
	<p>Wording translation: <b>ro99</b>  Indicated part: <b>Reverse Osmosis (RO) Module</b>  Interpretation: Remaining life 99% for RO Module</p>
	<p>Wording translation: <b>d199</b>  Indicated part: <b>Resin Deionizer (DI) Module</b>  Interpretation: Remaining life 99% for DI Module</p>
	<p>Wording translation: <b>du99</b>  Indicated part: <b>Off-Gas Destructor</b>  Interpretation: Remaining life 99% for Off-Gas Destructor</p>
	<p>Wording translation: <b>PF99</b>  Indicated part: <b>iEOG Pre-filter</b>  Interpretation: Remaining life 99% for iEOG Pre-filter</p>
	<p>Wording translation: <b>Bt99</b>  Indicated part: <b>Gus-Liquid Buffer Tank</b>  Interpretation: Remaining life 99% for Buffer Tank</p>
	<p>Wording translation: <b>Pc99</b>  Indicated part: <b>Check Valve for Pump Gas Inlet (PC)</b>  Interpretation: Remaining life 99% for PC</p>
	<p>Wording translation: <b>Fn99</b>  Indicated part: <b>Fans (all fans)</b>  Interpretation: Remaining life 99% for Fan(s)</p>
	<p>Wording translation: <b>oF99</b>  Indicated part: <b>Ozone Gas Solenoid Valve (OF)</b>  Interpretation: Remaining life 99% for OF</p>
	<p>Wording translation: <b>ou99</b>  Indicated part: <b>Off-gas Separator Seals (OU)</b>  Interpretation: Remaining life 99% for OU</p>

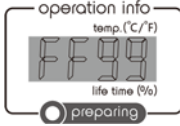
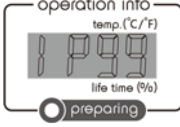
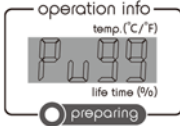
	<p>Wording translation: <b>FF99</b>  Indicated part: Safety Valve  Interpretation: Remaining life 99% for Safety Valve</p>
	<p>Wording translation: <b>IP99</b>  Indicated part: <b>iEOG Water Feed Input Pipe (IP)</b>  Interpretation: Remaining life 99% for IP</p>
	<p>Wording translation: <b>Pu99</b>  Indicated part: <b>Dissolving Pump Mechanical Contact Seal</b>  Interpretation: Remaining life 99% for Dissolving Pump Mechanical Contact Seal</p>

### 3.7 Conditionally Shut-Down Procedures

The OWS-1 unit is intended for constant power-on, unless in necessary situations, such as during machine servicing activities.

**The following sequence of steps must be followed for manual shut-down:**

1. Turn off the unit.
2. Shut off water supply for the iEOG feed.
3. Turn off the system by un-plugging the cord from the wall outlet.

## 4. MAINTENANCE

### 4.1 Service Notification

The OWS-1 unit will display various Service Codes as notifications to operators when standard service is required. The information is displayed in the “Service Code” screen. Please contact your regional BioSure Professional dealer for service arrangements when the code(s) are present.

For Remaining Lifecycle of any consumable part that is recorded, the unit will provide service notification once the service or replacement is required. The Service Notification will be displayed in two different modes according to the degree of urgency: “**2% Remaining Notification**” and “**Life Ending Notification**”:

#### 2% Remaining Notification

In this mode, “**Service Indicator**” is flashing in slow mode, and Service Code is displayed on the “**Service Code**” screen.



At this time, the operator should contact the local BioSure Professional service provider or dealer to schedule a service and part replacement within 3-week time.







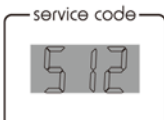

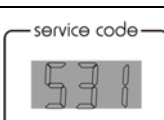
#### Life Ending Notification

In this mode, all functions are suspended. 10 beeps alarm are sounded when one tries to operate the unit, “**Service Indicator**” is flashing in quick mode, and Service Code is displayed on the “**Service Code**” screen.

At this time, the operator should contact the local BioSure Professional service provider or dealer to schedule a service and part replacement immediately.

The coding system for each service requirement and the interpretation is listed as follows:

Service Codes	Interpretation
	Wording translation: <b>S11</b> Coding Interpretation: Replace <b>iEOG Pre-filter</b>
	Wording translation: <b>S12</b> Coding Interpretation: Replace <b>Ozone Gas Solenoid Valve</b>
	Wording translation: <b>S13</b> Coding Interpretation: Replace <b>Dissolving Mechanical Contact Seal</b>
	Wording translation: <b>S31</b> Coding Interpretation: Replace <b>Reverse Osmosis (RO)</b>

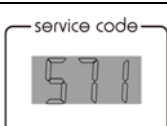
	<p>Wording translation: <b>S32</b> Coding Interpretation: Replace <b>Resin Deionizer (DI)</b></p>
	<p>Wording translation: <b>S33</b> Coding Interpretation: Replace <b>Gus-Liquid Buffer Tank</b></p>
	<p>Wording translation: <b>S34</b> Coding Interpretation: Replace <b>Off-Gas Destructor</b></p>
	<p>Wording translation: <b>S35</b> Coding Interpretation: Replace <b>Off-gas Separator Seals</b></p>
	<p>Wording translation: <b>S36</b> Coding Interpretation: Replace <b>Check Valve for Pump Gas Inlet</b></p>
	<p>Wording translation: <b>S37</b> Coding Interpretation: Replace <b>Safety Valve</b></p>
	<p>Wording translation: <b>S38</b> Coding Interpretation: Replace all <b>Fans</b></p>
	<p>Wording translation: <b>S39</b> Coding Interpretation: <b>Replace iEOG Water Feed Input Pipe</b> (iEOG Pre-filter pipes for both input &amp; output)</p>
	<p>Wording translation: <b>S71</b> Coding Interpretation: Coding Interpretation: Replace <b>iEOG Generator Module Set</b></p>

**These codes are removed only if the parts are replaced and after an authorized BioSure Professional service technician resets the records.**

## 4.2 Preventative System Maintenance

The following **Preventative Maintenance Schedule** is suggested according to various working environment and operator's quality control policy.

DAILY or WEEKLY

1. Make sure "warning" indicator is not illuminated and no buzzer sounds.



**EVERY 3 or 6 MONTHS**

1. Perform general cleaning of cabinet interior, remove visual dust and linen inside.
2. Check fans for proper operation and clean fans and fan screens.
3. Visual inspection of all plumbing works. Replace as required.

**ANNUALLY:**

1. Repeat the maintenance plan for every 6 months described above.
2. Follow Service Notification to replace the parts that are with one-year running cycle basis.

**EVERY TWO - THREE YEARS:**

1. Repeat the annual maintenance described above.
2. Follow Service Notification to replace the parts that are with two/three-year running cycle basis.

**4.3 System Servicing**

Regular service should be performed to avoid damage to the system, more costly repairs and to keep the warranty active.

Standard Replacement Cycle for the G-Series unit is a rule of thumb under the following conditions:

System **MUST** remain connected to water and power supply at all times.

Municipal water (or equivalent quality) is used for input.

Operating room temperature is in accordance with products instructions.

Operating input water temperature and the supply pressure are in accordance with products instructions.

The required standard service will be notified by the system through the display of the “**Service Notification**“. The information is displayed on “**Service Code**” screen when the work is required. The operator should contact the local BioSure Professional service provider for service. The related items as replacement in the service and the servicing cycles are as follows:

**Every 5000 working hours consumable parts (or every year)**

1. Pre-filter cartridge (for iEOG water input)
2. Ozone gas solenoid valve
3. Deionizer resin tank (1L)
4. Gas-liquid separation floater seal kit
5. Mixing Pump mechanical contact seal

**Every 15000 working hours consumable parts (or every 3-year)**

1. RO membrane assembly (50gal)
2. Ozone Generator (EOG EA1500)
3. Off-gas destructor (thermal)
4. Gas inlet titanium check valve (on pump)
5. Buffer tank assembly

**Every 30000 working hours consumable parts (or every 6-year)**

1. 1225 DC fan
2. 1225 Waterproof DC fan
3. 1238 DC fan, Qty=2

**4.4 System Operational Code**

The **Operational Code** is a record of the unit's operational history, containing 28 digits in groups of 7. To display the code, press "**setting**" key and hold it for 15 seconds, and then the first group of code with 4 codes will be displayed on the "**operation info**" screen. Meanwhile, a number from 1 to 7 will be displayed on the "**service code**" screen for group identifications. Press "**▲**" (page-up) or "**▼**" (page-down) to switch to each sequential group.

Your BioSure Professional service provider may ask for this information before service. The operator can use the following example table to note down all the codes as feedback:

Group No.	Digit 1	Digit 2	Digit 3	Digit 4
1				
2				
3				
4				
5				
6				
7				











**Note: The Operation Codes are for service technicians to interpret only.**

The unit's operational history is recorded as long as the power is on. The data represents the system's operation log. It is only intended for your service provider to interpret the codes when troubleshooting the unit. The recorded data can be used to access the following information:

- Product model code
- Total power on hours
- Pump operation hours
- Power disconnection counts
- Temperature alarm counts (E55&E56)
- iEOG water filling failure counts (E45)
- System firmware version

**Code Wording Index for Alphabet**



**Index to operation log coding**

<b>Display</b>					
<b>Alphabet</b>	o	i	r	H	4
<b>Display</b>					
<b>Alphabet</b>	F	d	G	E	c

## 5. TROUBLESHOOTING

### 5.1 Error Notification

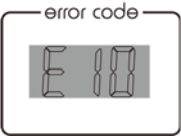
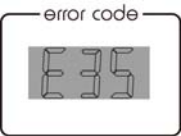
For following detectable errors, once detected, the codes will be displayed on “**Error Code**” screen:

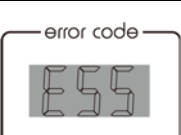
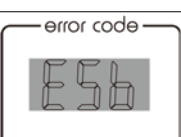
Error Codes	Interpretation
	Wording translation: <b>E10</b> Error Interpretation: iEOG Generator module fails. <b>All functions are suspended.</b>
	Wording translation: <b>E35</b> Error Interpretation: Input water pressure found too high. <b>All functions are suspended.</b>
	Wording translation: <b>E45</b> Error Interpretation: iEOG water refilling fails during preparation (2-hr timeout). <b>All functions are suspended.</b>
	Wording translation: <b>E55</b> Error Interpretation: System internal temperature found too high (>56°C). <b>All functions are suspended.</b>
	Wording translation: <b>E56</b> Error Interpretation: Internal water temperature found too high (>56°C).

The OIP indicators and system buzzer are engaged in the warning notifications as well:

Error Code	E10	E35	E45	E55
Warning Indicator	Flash Fast			
Preparing Indicator	NA		Flash Fast	NA
Buzzer	10 Beeps			

## 5.2 Troubleshooting Procedures

The OIP will provide immediate code notification of self-detectable system faults. The sections below list various faults that may be encountered during normal operation, along with typical causes and potential corrections.

### Symptom: System do not start

CAUSE	SOLUTION
No Power	Verify that main supply conductors are properly connected and that correct voltage is present.
Bad Power Unit(s)	Contact your BioSure Professional dealer or service provider for service.

### Symptom: No ozone concentration in output; no error displayed

CAUSE	SOLUTION
Loosen Connection	Open the removable covers and identify the leaking position. Fasten the connection.
Cracking/Broken Component	Contact your BioSure Professional dealer or service provider for service.

### Symptom: Ozone leakage detected

CAUSE	SOLUTION
Loosen Connection	Contact your BioSure Professional dealer or service provider for service immediately.
Cracking pipes	
Bad Ozone Gas Solenoid Valve	
Bad Off-Gas Destructor	

### Error Code: E10

#### All functions are suspended.

Error Message: Failures of iEOG Modules are detected with a major reason that the operating voltage is found too low.

CAUSE	SOLUTION
Bad iEOG Cell(s)	Contact your BioSure Professional dealer or service provider for service and replacement.

**Error Code: E35**

**All functions are suspended.**

Error Message: Input water pressure found too high.

CAUSE	SOLUTION
High Pressure	Correct input water pressure and then re-start the unit.

*Note: Refer instructions in Section 3.5 for “Re-Start” procedures.*

**Error Code: E45**

**All functions are suspended.**

Error Message: iEOG water refilling timeout

CAUSE	SOLUTION
Low Pressure	Correct input water pressure and then re-start the unit.
iEOG Pre-filter jammed	Clean or replace as needed and then re-start the unit.
Others	Contact your BioSure Professional dealer or service provider for service.

*Note: Refer instructions in Section 3.5 for “Re-Start” procedures.*

**Error Code: E55**

**All functions are suspended.**

Error Message: System temperature found too high (>56°C).

CAUSE	SOLUTION
High Ambient Temp.	Correct ambient temperature or enhance on-site air-cooling performance and then re-start the unit.
Bad fan(s)	Contact your BioSure Professional dealer or service provider for service.

*Note: Refer instructions in Section 3.5 for “Re-Start” procedures.*

**Error Code: E56**

**All functions are available for use.**

Error Message: Inside water temperature found too high (>56°C).

CAUSE	SOLUTION
Improper Input Temp.	Check the input water temperature.
Bad fan(s)	Contact your BioSure Professional dealer or service provider for service.

## 6. VALIDATION

For accurate performance validation – measure your dissolved ozone ppm in the output, the distance between the unit's outlet and the opening of the validation point should be within 1 m and a hand shut-off valve should be installed for the point. The unit should remain in standby for at least 30 minutes before starting the validation.

To proceed performance validation:

1. Allow flow from the validation point for at least 10 seconds to start the unit.
2. Take samples from the validation point for concentration measurement.
3. You may take 3 – 5 samples at a time for average.

Please contact your local BioSure Professional dealer for the standard criteria for the validation and available validation tools from BioSure Professional.



### Directions of Use for OM-100

Ozone has a short half-life and leaves no residues. Therefore, to overcome ozone's hard-to-detect properties, BioSure Professional provides a simple titration kit – OM-100, which can be used to ensure your unit is actively providing ozone for disinfection and sanitation in various applications you want. This kit can be found in the accessory box.

OM-100 includes easy-to-use dropper bottle containing dissolved ozone titration reagent to quickly and effectively establish measures for the presence of dissolved ozone in a sample. Just simply pour 200 ml of ozonated water into a beaker, drip the OM-100 until light blue is present. This measures the ozone concentration in the sample instantaneously by manner of titration and measuring the oxidation.

You can also check the video for the use of OM-100 on YouTube - Key Word: How to Use OM-100. For ordering OM-100, contact your local BioSure Professional dealer.

<b>Step 1</b>	 <p>200 ml</p>	<ol style="list-style-type: none"> <li>1. Prepare OM-100 in hand and then take sample 200 ml.</li> </ol> <p><b><i>Note: After observing outflow, allow it to flow for 5 to 10 sec before taking samples.</i></b></p>
---------------	---	--

<b>Step 2</b>	 	<ol style="list-style-type: none"><li>1. Apply the first drop, if the result is:<ol style="list-style-type: none"><li>a. Sample shows light blue, meaning the sample is below 1.0 ppm.</li><li>b. Clear, see no change in transparency, meaning the sample is above 1.0 ppm, you can try to apply the 2nd drop.</li></ol></li><li>2. Following 2-1, apply 2nd drop, if the result is:<ol style="list-style-type: none"><li>a. Sample shows light blue, meaning the sample is below 2.0 ppm (1.0 ~ 2.0).</li><li>b. Still clear, see no change in transparency, meaning the sample is above 2.0 ppm, you can try to apply the 3rd drop.</li></ol></li><li>3. You may carry on the test and more drops may be applied depending on the actual ppm of the sample.</li></ol>
---------------	--	--